

Vertical and Diagonal Earth Loops

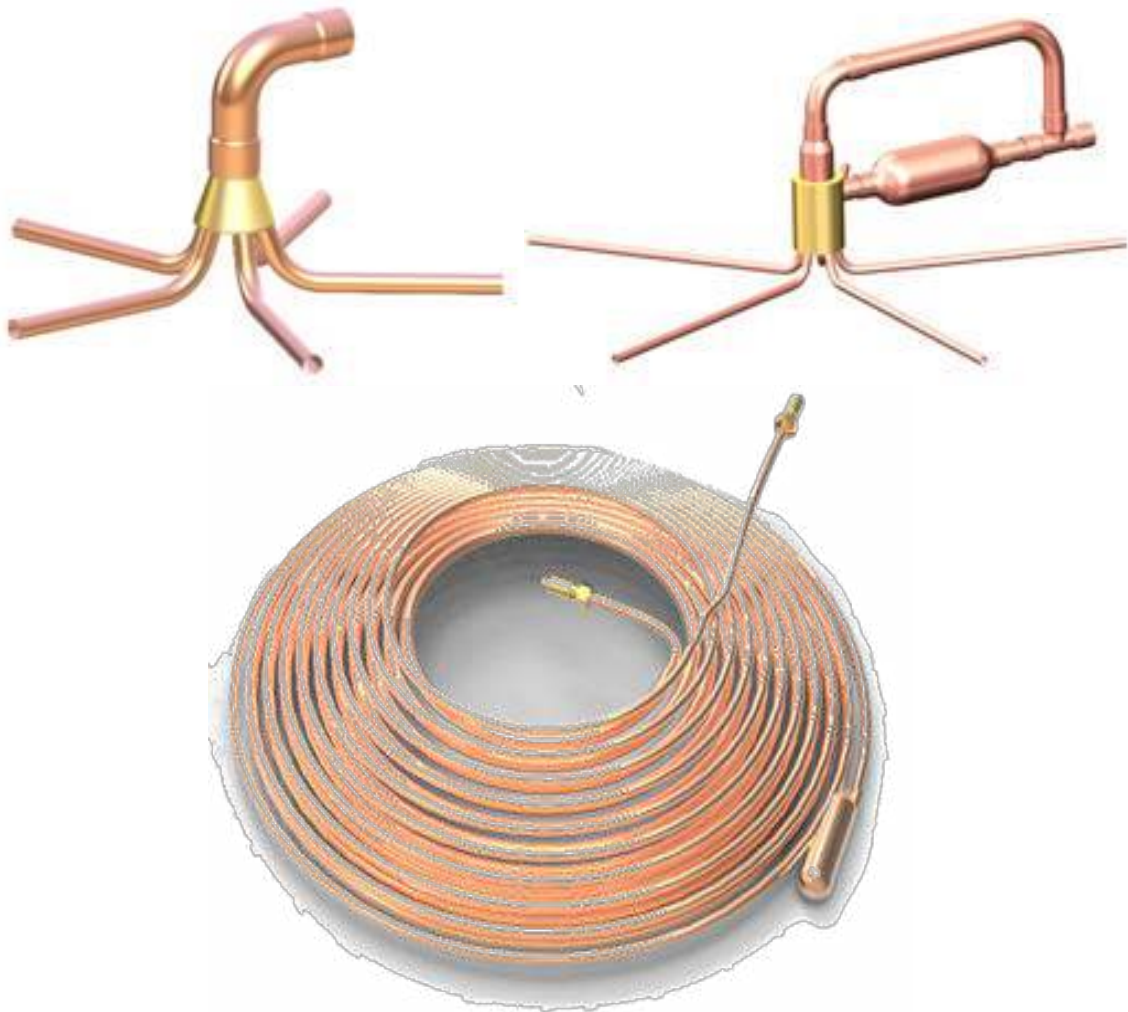

Installation Instructions

Disclaimer

Proper installation of the Total Green Mfg. Earth Loop is essential to its reliable performance. All Total Green Mfg. systems must be installed and serviced by a qualified HVAC contractor. Equipment sizing, selection and installation are the sole responsibility of the installing contractor. Installation must be made in accordance with the instructions set forth in this manual. Failure to provide installation by a qualified HVAC contractor in a manner consistent with this manual will void and nullify the limited warranty coverage for the system.

Total Green Mfg. shall not be liable for any modification(s), defect, unsatisfactory performance, damage or loss, whether direct or consequential, relative to the design, manufacture, application or installation of any field specified components.

All commissioning and registration paper work must be filled out at start up and returned to Total Green Mfg. for full warranty coverage.

Introduction: Total Green Mfg. has designed the Earth Loop System to function as the underground component of the Waterless™ Geothermal Heating and Cooling System. Total Green Mfg. manufactures and sells this system, performance certified under ARI Standard 870-99 and safety certified by ETL under applicable UL Safety Standards.

Waterless™ Geothermal systems provide performance and efficiency advantages to the end user consistent with safeguarding the environment, as a result of employing specific design, manufacturing and installation practices.

Total Green Mfg. utilizes ACR Type coiled copper tubing in sizes ranging from ¼" OD to ½" OD in its Earth Loop Systems. This ACR Type copper tubing meets the requirements of Standard ASTM B 280.

Table of Contents

Specifications, Compliances and Restrictions.....	Pages 4 and 5
Approved Grouts and Selections.....	Pages 6, 7 and 8
Options for Acidic and Adverse Soil Conditions.....	Page 9
Line Set Lengths and Elevations.....	Page 10
General Description.....	Pages 11 and 12
Site Perperation and Bore Holes, Diagonal Drilling.....	Page 13
Diagonal Drilling Templates.....	Pages 14 and 15
Site Perperation and Bore Holes, Vertical Drilling.....	Page 16
Vertical Drilling Templates.....	Page 17
Earth Loop Installation.....	Page 18
Grouting.....	Pages 19 and 20
Anode Installation (Cathodic Protection).....	Pages 21,22 and 23
Manifold Installation.....	Pages 24, 25 and 26
Soaker Line.....	Page 27
Line Set.....	Pages 28, 29, 30, 31 and 32
Seal Test.....	Page 33
Back Filling.....	Page 34
R-410A Quick Refrence Guide.....	Page 35

Specification, Compliances and Restrictions

This manual addresses the specification and installation of Waterless™ Geothermal Earth Loop Systems with Waterless™ Geothermal Heating and Cooling Systems.



WARNING!

- 1) **DO NOT** install an earth loop system in soils with high concentrations of acids, chlorides, sulfides, sulfates, carbon, coal, cinders or ammonia; or organic soils with anaerobic bacteria, or in coastal areas with brackish water marshes, salt water intrusion or acidic peat bogs. Prior to drilling or excavation for the Earth Loop system, it is the responsibility of the system specifier to determine the presence of these noted concentrations by taking soil samples at appropriate depths below the ground surface and at multiple locations within the intended Earth Loop field. Further, if concerns regarding the above conditions exist, the soil should be sampled, analyzed and documented by a licensed soil testing laboratory.
- 2) It is not recommended to install an Earth Loop system within one half (1/2) mile of a salt water sea shore or any tidal body of water.

Earth Loop systems installed in any of the above conditions without first consulting Total Green Mfg. for the appropriate installation method will void the Total Green Mfg.'s Limited Warranties for the copper earth loops, manifolds and all equipment connected to the earth loop system.

Should these conditions be encountered, please consult with Total Green Mfg. Technical Support for the appropriate methods for installing an Earth Loop field.

The specification of an earth loop system begins with a Manual “J” load calculation, the correct sizing and selection of the system based on the Manual “J” along with using Total Green Mfg.’s **“System Sizing and Selection”** manual and, a thorough site evaluation to determine the appropriate loop field type and location.

The following site restrictions apply to drilling or excavation operations relative to all Waterless™ Geothermal earth loop configurations:

- As part of the specification process, verify with appropriate local utilities that there are no other existing underground impressed current protection systems which would electrically interfere with the Waterless® Geothermal cathodic protection system.
- Before excavating or drilling, the site must be inspected to ensure the absence of electric, gas, water, sewer, irrigation and telephone lines.
- Excavations are subject to OSHA regulations (Federal Register; Volume 54; No. 209; Oct. 31, 1989. Rules and Regulations page 45965 [29 CFR Part 1926]). Earth loop installations are not to be within:
 - a. 12 feet of a foundation, water line or drainage zone of a building downspout.
 - b. 50 feet off a water well, or below the collection basin of de-icing salts or barnyard runoff.
 - c. 75 feet off septic system and leach field.
 - d. One-half the branch extremities of a tree or a shrub.

Specification, Compliances and Restrictions

The use of copper in earth loops is compatible with over 90% of the land area in North America.

- **Soil samples are to be tested to determine pH value.** Total Green Mfg. recommends that soil be sampled, analyzed and documented as per your jurisdiction and local code requirements. For soil conditions where the **pH is 6** or lower, encasing the loop is **required**. A high quality soil pH tester sold at gardening and farm supply stores can be used as reference.

Pulverized Limestone can be used in place of mason sand for packing manifolds and protecting line sets. Pulverized Limestone can help raise the pH value of aggressive soils. **Please Note:** Pulverized Limestone is **NOT** to be used for mixing grout. Grout should only be mixed with silica sand as per the grout manufacturer's instructions



IMPORTANT!

Waterless™ Geothermal compressor units that provide space cooling shall be equipped with a Waterless™ Geothermal Hybrid Cooling Module (HCM) when:

- (1) System is in a cooling dominant application where soil thermal conductivity is known to be poor. Examples of such soils are light dry soil, dry sand, peat and organic soils, dry clay and hardpan (a layer of soil impervious to water); OR
- (2) In any system where the outdoor temperatures have exceeded the outdoor summer design temperature conditions causing a continuous system run time of 4 or more hours in a day; OR
- (3) In any system where indoor design conditions have exceeded the designed cooling load and system capacity causing a continuous system run time of 4 or more hours in a day. Examples of such would be offices, classrooms and church environments that see high occupancy during the day but, would otherwise have equipment grossly oversized the rest of the time.

Please refer to Total Green Mfg.'s Waterless™ Geothermal Hybrid Cooling Module Manual for more information.



IMPORTANT!

Only Total Green Mfg. factory trained technicians who meet local, state and federal proficiency and licensing requirements are qualified to install and service Earth Loops in accordance with these instructions and the local code authority having jurisdiction.

Approved Grouts & Selections

All Boreholes must be thoroughly grouted. Grout must be installed from the bottom of the borehole to the top of the borehole, utilizing a Tremie Tube (to pump the grout to the bottom of the hole) and an appropriate pump designed to work with the type of grout being used. The mixing ratio required for a Waterless® Geothermal Copper Loop field must equal a mix ratio that meets or exceeds a thermal conductivity value of at least 1.0 when using any bentonite type grout. Grout all boreholes using only one of the Total Green approved grouts from the following list:

Company	Grout Type	Grout Name	Additive(s)	Minimum Size Tremie Tube	Grout Consistency
TCC	Cementitious	Thermaseal - Hi Flow	None	1/2" Tube	Rigid
TCC	Cementitious	Thermaseal - Hi Yield	None	1/2" Tube	Rigid
NA	Cementitious	BNL-111***	Bagged Silica Sand, Portland Cement, & Superplactisizer	1 1/4" Tube	Rigid
Cetco ¹	Bentonite	Premium Gel	Bagged Silica Sand	1 1/4" Tube	Pliable
Baroid	Bentonite	Barotherm Gold	Bagged Silica Sand	1 1/4" Tube	Pliable
GeoPro	Bentonite	Thermal Grout Select & Thermal Grout Lite	Bagged Silica Sand	1 1/4" Tube	Pliable
Wyo-Ben	Bentonite	Therm-Ex	Bagged Silica Sand	1 1/4" Tube	Pliable

¹ Cetco High TC grout is NOT Approved

Selecting the Proper Grout

Each grout type has its specific purpose for being used based on the application & geographic region. Geographic location and the dominant (Heating or Cooling) load will determine the type of grout you should use. Cementitious (Cement-based) grouts should only be used in moderate and cold temperature regions that have Heating dominate loads. Cementitious grouts become rigid and are not pliable after the grout has cured like bentonite. For this reason, it is not recommended to use a cement-based grout in Southern Regions that contain heavy clay and are typically Cooling Dominant. Each of our approved thermal grouts have specific ingredients and should be mixed as specified by the grout manufacturer to achieve at least a 1.0 thermal conductivity or greater. Curing times will differ from one grout type to another, so you must follow the manufacturer's instructions to allow for proper cure times.

Bentonite grouts can be used in most applications, however are limited in some. Typically, a bentonite grout will draw or wick moisture from the surrounding earth causing the grout column to remain pliable and conform to the soil as it expands and contracts during periods of no rain or dry ground conditions. Bentonite grout is ideal for hot regions across the country. Never use graphite as a grout additive to increase its thermal conductivity.

Thermaseal grout is a thinner and more fluid grout, making it easier to pump. If the earth loops are being encased in a pipe, Thermaseal grout is required to fill the inner pipe as part of this pre-engineered loop design. This is when a 1/2" grout "tremie" tube must be used to pump the grout to the bottom of the inner pipe.

Grout Selection Chart	
Drilling Application	Heating or Cooling Dominant
Heavy Clay	Bentonite Only
Sand	Thermaseal or Bentonite
Gravel	Thermaseal or Bentonite
Rock	Thermaseal or Bentonite
Any of the above & Rock	Thermaseal or Bentonite
Light Clay & Soil	Thermaseal or Bentonite
Soil Water	Thermaseal or Bentonite
Encased Loop Inside Casing	Thermaseal Only
Encased Loop Outside Casing	Thermaseal or Bentonite

Grout Minimum Thermal Conductivity (K-Value) Requirements				
LOOP FIELD CONFIGURATION	ENCAPSULATED LOOP	DRY SOIL ¹ (BARE LOOP)	COOLING DOMINANT (BARE LOOP)	HEATING DOMINANT (BARE LOOP)
V1PLUS/D1PLUS LOOP DESIGN ² 1-100' LOOP PER TON PLUS 1 LOOP	1.0 Btu/hr-ft-°F	1.0 Btu/hr-ft-°F	1.0 Btu/hr-ft-°F	1.0 Btu/hr-ft-°F or 0.75 Btu/hr-ft-°F
D2 LOOP DESIGN ² 2-70' LOOPS PER TON	1.0 Btu/hr-ft-°F	1.0 Btu/hr-ft-°F	1.0 Btu/hr-ft-°F	1.0 Btu/hr-ft-°F or 0.75 Btu/hr-ft-°F

¹ Dry soil is classified by not hitting moist soil or water within the first 50% of the borehole depth.

² V1Plus /D1Plus/D2 Loop Designs are allowed for either heating or cooling dominate loads

Characteristics of Thermaseal - Cementitious Grout

Thermaseal grout is a one bag mix and does not require mixing any other ingredients (such as sand) or other additives with it in the field. This makes Thermaseal a very fluid cement-based grout. Thermaseal is not too thin or fluid to seal borehole cracks and crevices. It also has the unique ability to close in most borehole blowouts.

Maintaining a thinner fluid (similar to a runny milkshake) allows the grout to be pumped very easily. This cement-based grout will set up in a solid or rigid column similar to cement. Thermaseal will set up faster (24-48 hours) than a traditional bentonite grout, which prevents the grout from becoming brittle and losing its thermal conductivity if exposed to an extreme cold condition too quickly. Another benefit of a fluid grout like Thermaseal is the ability to be pumped down a smaller (½ inch to ¾ inch) diameter tremie tube. Consequently, this also allows you to drill a smaller diameter borehole and use less grout.

Typically, less maintenance on the grout pump is required when using the thinner Thermaseal grout since there is no sand to wear down the internal pump components, which results into less pump re-builds, less down time and less shop time.

If the earth loops are being encased in a 1½" schedule 21 PVC pipe, it is necessary to use Thermaseal grout to fill the inside of the PVC pipe using a ½ inch tremie tube. Thermaseal grout is not

recommended to be used in southern regions that contain heavy clay soils and long periods of hot dry spells, as the clay soil will contract as it dries up and pull away from the solid grout column.

Characteristics of Bentonite Grout

Bentonite type grouts are mixed in the field and require additives such as silica sand (do not use ordinary mason sand or bulk sand as a substitute) to be added when mixing. Using bagged silica sand ensures the grout has the characteristics and properties described by the manufacturer to reach the thermal conductivity levels described in the mixing instructions. Bentonite grouts typically have a thicker consistency and require the use of a traditional paddle mixer and piston pump. Be sure to allow for proper curing times (per the manufactures specifications) for a bentonite grout. Pumping Bentonite grout also requires the use of a larger diameter tremie tube (1 – 1 ½ inch), along with a larger diameter borehole to accept the larger tremie tube. Typically, bentonite type grouts remain pliable and do not solidify or become rigid after setting up (which can act as an advantage for soils that constantly expanding and contracting from one season to another) Use the mixing ratio that achieves a minimum of a 1.0 BTU/hr.ft.°F thermal conductivity for DX copper earth fields. Mixing ratios of sand (that meet a thermal conductivity level of at least 1.0 BTU/hr.ft.°F) to bentonite can reduce the odds of the grout column shrinking and pulling away from the surrounding earth. Do not add graphite or other thermal conductivity enhancers to the grout as they can have an adverse effect on the copper loop.

Characteristics of Mix BNL-111 - Cementitious Grout

BNL-111 grout mix will create a grout column that is more rigid and has longer cure times. Mix BNL-111 is a universal grout mix that needs to be mixed in the field using multiple ingredients. BNL-111 grout is much thicker than the Thermaseal cement-based grout since sand is a required additive. BNL-111 requires the use of a traditional paddle mixer and piston pump. This mix combines bentonite, sand and Portland cement and has been universally approved across the country for areas of acidity and in salt water applications, however, Total Green recommends encasing the loops in these conditions. If you are in areas of saltwater do not use a Bentonite type grout. BNL-111 grout mix has a thicker consistency and requires the use of a 1- 1½ inch tremie tube. Adding a superplasticizer per the BNL-111 Mix instructions to the grout will increase the pump-ability of the grout. The use of BNL-111 grout requires pre-approval by Total Green Mfg. Call Total Green Mfg. for approved applications and mixing instructions.



IMPORTANT

Do not over-water the grout to facilitate pumping as this is detrimental to thermal conductivity and permeability and will negatively impact the performance of the grout.

OPTIONS FOR ACIDIC OR ADVERSE SOIL CONDITIONS

1. ENCASED LOOP SYSTEM

- For conditions such as salt water, Low pH, and high sulfur soil conditions, we recommend to encase the copper loop in PVC pipe. After encasing the loop inside a PVC pipe, grout the inside of the PVC casing with a cementitious grout. This type of grout flows easier and can be pushed through the smaller Tremie pipe needed to fill the PVC pipe from the bottom up. The grout selected and used outside the PVC pipe between it and the earth should be a grout appropriate for the ground conditions, either cementitious or bentonite grouts. For soil conditions where the **pH tested 6** or lower, encasing the loop is **required**. Please refer to the “Encasing Earth Loop Instructions” manual.



2. HYBRID COOLING MODULE

(1) System is in a cooling dominant application where soil thermal conductivity is known to be poor. A Hybrid Cooling Module is required. Examples of such soils are light dry soil, dry sand, peat and organic soils, dry clay and hardpan (a layer of soil impervious to water); **OR**

(2) In any system where the outdoor temperatures have exceeded the outdoor summer design temperature conditions causing a continuous system run time of 4 or more hours in a day; **OR**

(3) In any system where indoor design conditions have exceeded the designed cooling load and system capacity causing a continuous system run time of 4 or more hours in a day. Examples of such would be offices, classrooms and church environments that see high occupancy during the day but would otherwise have equipment grossly oversized the rest of the time.

Please refer to Total Green Mfg.’s Waterless™ Geothermal Hybrid Cooling Module Manual for more information.

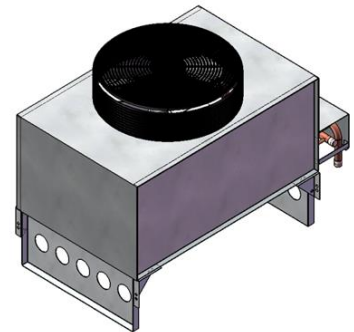

Line Set Lengths and Elevations

Total equivalent line set lengths and elevations must be strictly followed. Equivalent meaning accounting for frictional loss of fittings and connections. This is **NOT** linear feet. Please carefully review the below illustration when planning a Waterless Geothermal™ installation.

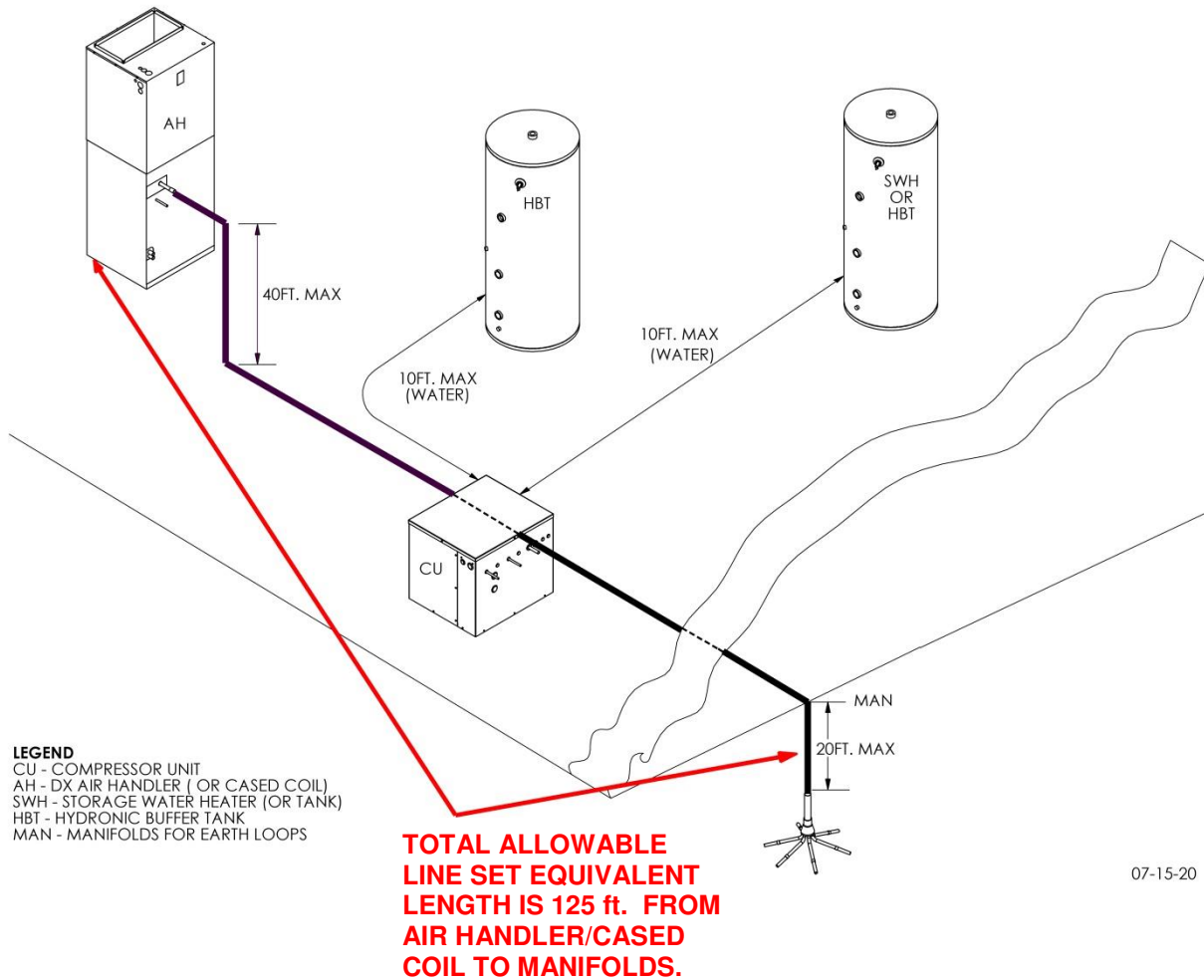

07-15-20

Pipe Fitting Equivalent Lengths

Long Radius 90 = 3 ft. - Coupling = 1 ft. - Swaged Connection = 1 ft.
 45 Degree Elbow = 1.5 ft.

Important Note: Short Radius 90° elbows are NOT permitted to be used in any piping.

General Description

D/V1P 100 ft. LOOPS, identified by Blue colored tape at the Schrader port, DIAGONAL or VERTICAL (1 LOOP PER TON PLUS 1)

Unit Size	No. of Loops	Model No.
2 Ton (24)	3 Loops	D/V1P-024-3
2.5 Ton (30)	3 Loops	D/V1P-030-3
3 Ton (36)	4 Loops	D/V1P-036-4
3.5 Ton (42)	4 Loops	D/V1P-042-4
4 Ton (48)	5 Loops	D/V1P-048-5
4.5 Ton (54)	5 Loops	D/V1P-054-5
5 Ton (60)	6 Loops	D/V1P-060-6
5.5 Ton (66)	7 Loops	D/V1P-066-7
6 Ton (72)	7 Loops	D/V1P-072-7

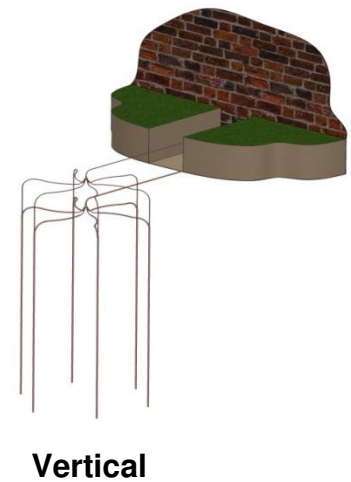
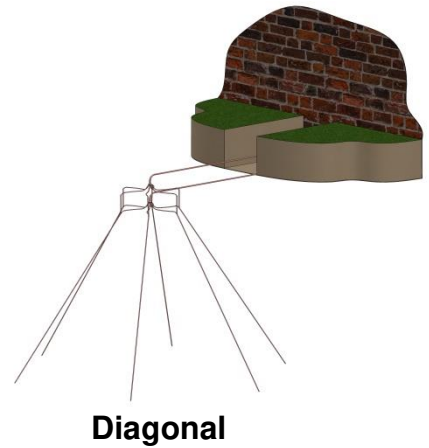

General Description

D2 70 ft. LOOPS, identified by Green colored tape at the Schrader port, DIAGONAL ONLY (2 LOOPS PER TON)

Diagonal installation only.

Unit Size	No. of Loops	Model No.
2 Ton (24)	4 Loops	D2-024-4
2.5 Ton (30)	5 Loops	D2-030-5
3 Ton (36)	6 Loops	D2-036-6
3.5 Ton (42)	7 Loops	D2-042-7
4 Ton (48)	8 Loops	D2-048-8
4.5 Ton (54)	9 Loops	D2-054-9
5 Ton (60)	10 Loops	D2-060-10
5.5 Ton (66)	11 Loops	D2-066-11
6 Ton (72)	12 Loops	D2-072-12

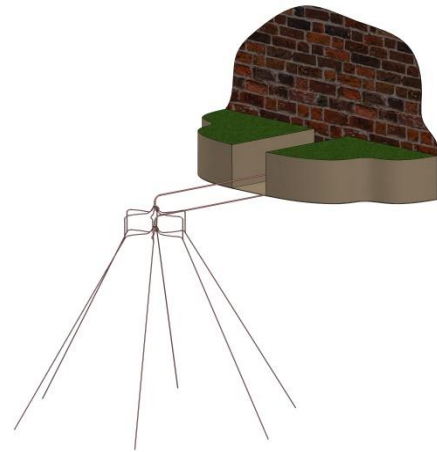

Diagonal Only



IMPORTANT

All Earth Loop fields, regardless of type or installation, must be no less than 12 feet away from a foundation wall as measured from the closest loop to that foundation wall. This is to prevent damage to the foundation wall from the potential forming of ice during the heating season.

Site Preparation and Bore Holes, Diagonal Drilling



IMPORTANT

Diagonal bore holes are to be drilled on a specific uniform angle from vertical. It is critical that the drilling angle for each borehole be the same. If not, performance of the system will be negatively impacted, and could result in system failure. Loop lengths are not to be modified or altered in any way.

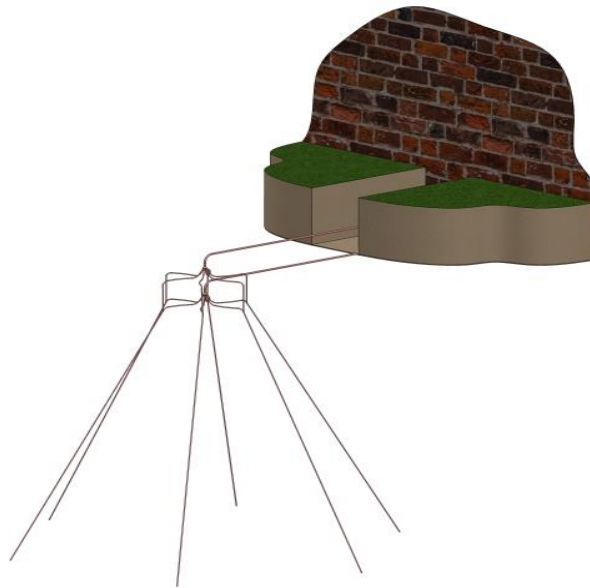

Diagonal Earth Loops

It is recommended to start by digging at least a 3 ft. diameter header pit. The depth of the pit should be 4 ft. deep or 1.5 ft. below the frost line for the region the loops are being installed, whichever is greater. Drill bore holes at least 3" in diameter to allow for appropriate grouting operations. The recommended drilling angle is 30 degrees from vertical based on the drill mast. This places the loop at a 60 degree angle below ground from grade. Angles from 15 to 45 degrees are acceptable. All bore holes **MUST** maintain the same **angle**. All bore holes **MUST** maintain the same **depth**.

Maintain each earth loop the same length. Do not shorten an earth loop and assure enough loop extends from the bore hole to maintain a sweeping path to the manifolds for expansion and contraction of the copper tubing. Failure to do so will result in manifold connection failure and leaks. It is critical that each earth loop have the same length and depth to ensure equal refrigerant flow through each loop. Carefully unroll the loop when inserting it into the bore hole so as not to kink the tubing.

Diagonal Drilling Templates for D1P Fields

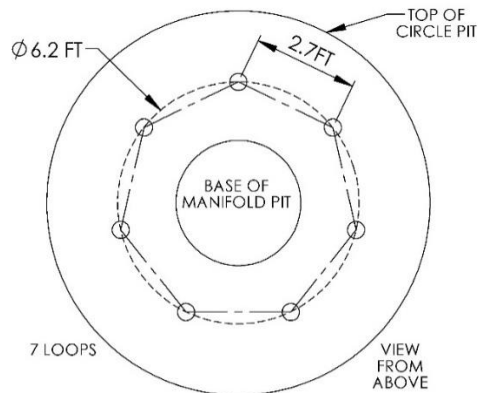
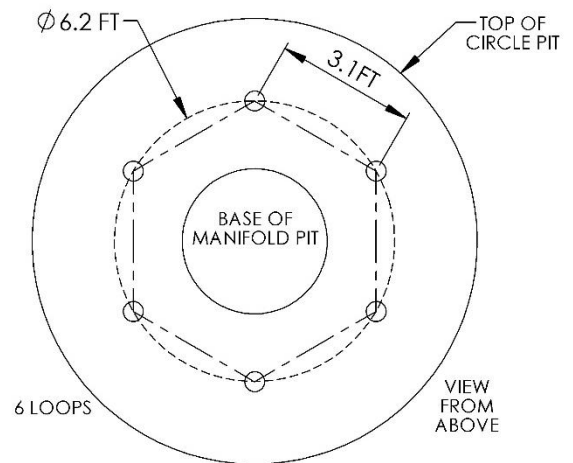
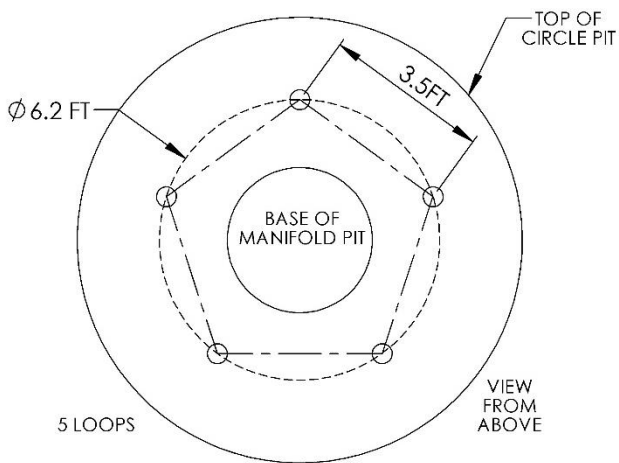
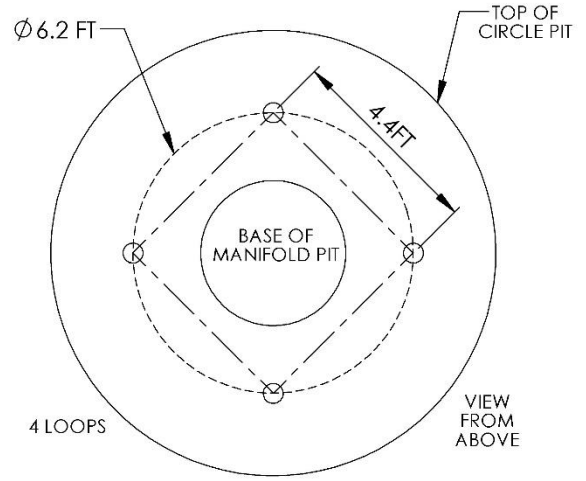
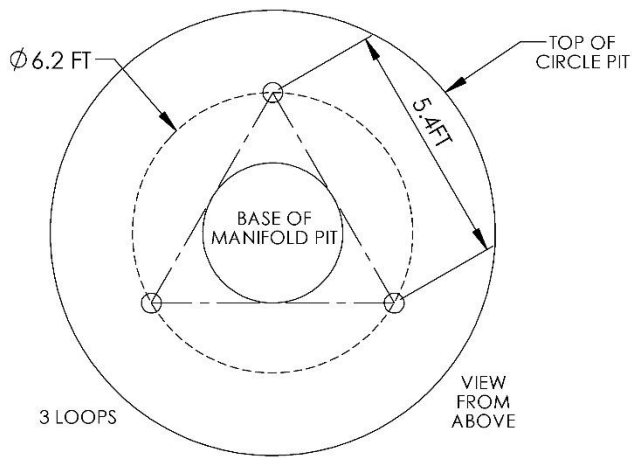

Diagonal Drilling Templates for D2 Fields

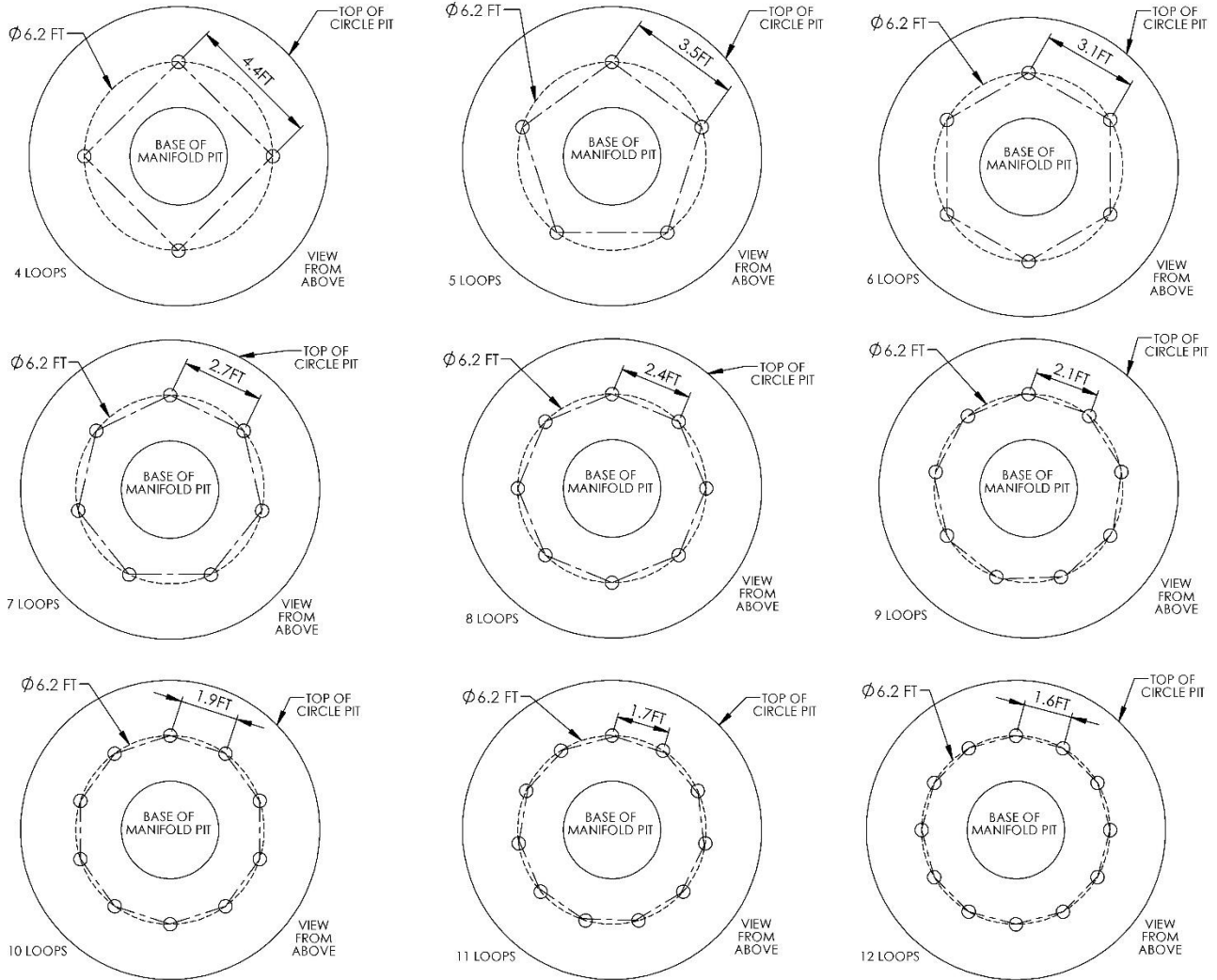

Site Preparation and Bore Holes, Vertical Drilling



IMPORTANT

Vertical boreholes are to be drilled to uniform depths. It is critical that the depth of each borehole be the same. If not, performance of the system will be negatively impacted, and could result in system failure. Loop lengths are not to be modified or altered in any way.

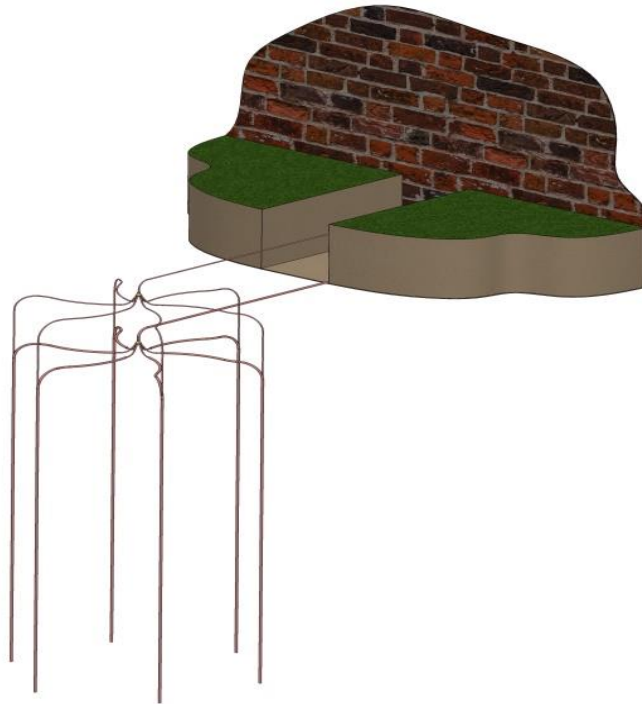

Vertical boring for use with 100 ft. loops require a spacing of 7 ft. between each bore hole. It is recommended that prior to drilling, the boreholes be mark for the correct spacing in a circle. Maintain boreholes and loop depths. The depth of the pit should be 4 ft. deep or 1.5 ft. below the frost line for the region the loops are being installed, whichever is greater. Drill bore holes at least 3" in diameter to allow for appropriate grouting operations. All boreholes **MUST** maintain the same **depth**.

Maintain each earth loop the same length. Do not shorten an earth loop and assure enough loop extends from the borehole to maintain a sweeping path to the manifolds for expansion and contraction of the copper tubing. Failure to do so will result in manifold connection failure and leaks. It is critical that each earth loop have the same length and depth to ensure equal refrigerant flow through each loop. Carefully unroll the loop when inserting it into the borehole so as not to kink the tubing.

Vertical Drilling Templates for V1P Fields

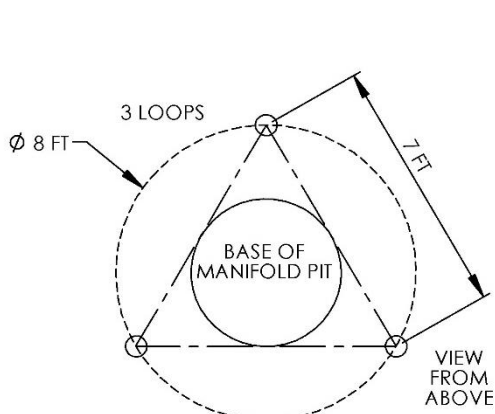

Est. Borehole Depth = 94 ½ ft
 Est. Loop Borehole Depth = 91 ½ ft
 Loop Outside Borehole = 5 ½ ft

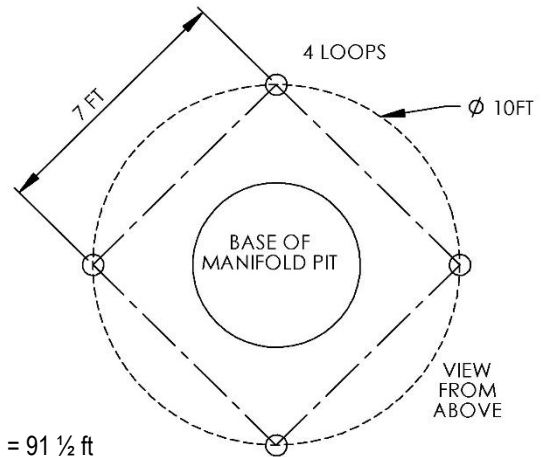

Est. Borehole Depth = 93 ½ ft
 Est. Loop Outside Borehole = 6 ½ ft

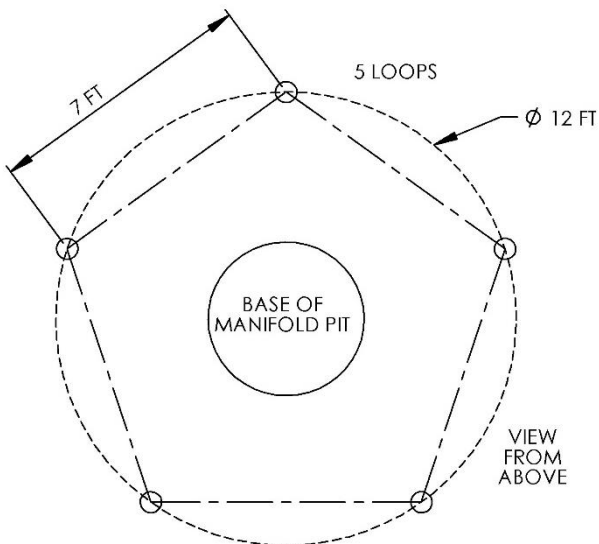

Est. Borehole Depth = 92 ½ ft
 Est. Loop Outside Borehole = 7 ½ ft

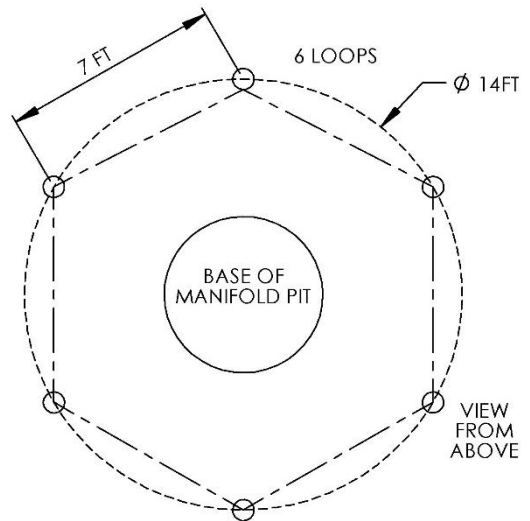

Est. Loop Borehole Depth = 91 ½ ft
 Est. Loop Outside Borehole = 8 ½ ft

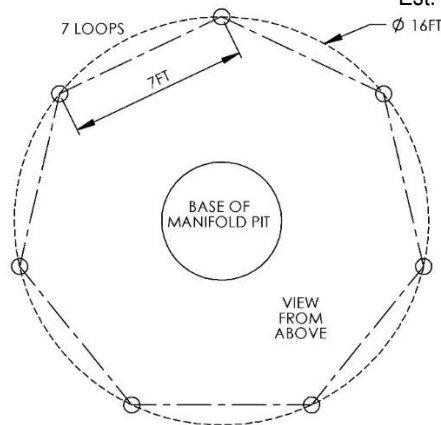

Est. Loop Borehole Depth = 90 ½ ft
 Est. Loop Outside Borehole = 9 ½ ft

Earth Loop Installation

The earth loop boreholes are drilled to a depth appropriate to accept the specified earth loops. The installer should check the earth loop to see that it is sealed, by quickly depressing and releasing the service valve stem at the end of the earth loop liquid (smaller) tube. The rushing sound of escaping nitrogen gas ensures that the earth loop is sealed.



WARNING

DO NOT CUT Earth Loop tubing unless it is first depressurized through the service valve. Cutting pressurized tubing can cause bodily injury.

The pressurized coiled earth loop is uncoiled and straightened in 4 to 6 ft. lengths (as a minimum), and inserted into the borehole. As an option, a flexible grouting hose (tremie tube) may be fed into the borehole with the earth loop, at the same time. If the diameter of the drilled borehole is large enough, the grouting hose can be inserted after the earth loop has been lowered into place. The method is the installer's choice.



IMPORTANT

After the bore hole has been drilled, the earth loop is to be installed and grouted as soon as practical to avoid the potential for the collapse of the bore hole and contamination of groundwater or aquifers.



IMPORTANT

To ensure satisfactory earth loop heat transfer, grout must be in complete contact with the earth loop over the entire diagonal or vertical length of the tubing.

After each earth loop is installed in the borehole and grouted as appropriate, the earth loop pressure is checked again to ensure the assembly has maintained its seal during installation. The pressurized nitrogen is not entirely released from each earth loop until the earth loops are ready to be connected to the manifolds.

Grouting



CAUTION!

Grout must be utilized with all vertical and diagonal Earth Loop systems and mixed to yield a minimum thermal conductivity of at least 1.0 BTU/H-Ft-°F, except where local codes and regulations specify otherwise. Grout shall be installed continuously from the bottom of the borehole up, to ensure maximum earth contact and to prevent voids. **SAND NOR BOREHOLE TAILINGS SHALL NOT BE USED FOR GROUTING.**

Not using a grout authorized by Total Green Mfg. during earth loop installation, will void the Limited Warranty on the entire Earth Loop System.

Be sure to read and understand the grout mixing instruction per the grout manufactures' instructions.



CAUTION!

Information given in this section serves as general guidelines only. Installers should **FOLLOW THE GROUT MANUFACTURER'S INSTRUCTIONS.** Failure to follow the grout manufacturers' instructions will void the Total Green Mfg. Limited Warranty on the entire Waterless™ Geothermal System.



IMPORTANT

When commissioning a system, if the grout manufacturer requires it, wait for curing time to be over. **Curing time ensures that the ultimate setting and hardness is reached.**

In the case of cementitious grouts, they go through a thermal chemical reaction and might need the whole curing time to achieve the target Thermal Conductivity.

Grouting



- 1) Once each Earth Loop has been placed in the borehole, the loop should be pressure grouted from the bottom up using a tremie pipe.
- 2) This pipe is to be inserted into the bottom of the borehole so grout can flow from the bottom up.
- 3) Once grout is to the top of the borehole, pause for a few minutes to allow grout to flow into any voids or irregularities. Add grout as needed until the grout level remains at the top of the borehole.
- 4) At this point, the tremie pipe can be slowly pulled out. While pulling the tremie pipe, continue to add grout until the tremie pipe is completely removed so as to fill the space void left by the tremie pipe.

Earth Loop Configuration	V1P,D1P 100 ft. Deep		D2 70 ft. Deep	
	Bore Hole Diameter (inches)	3 inches	4 inches	3 inches
Thermal Grout per Bore Hole (US Gallons)	35	64	27	48



IMPORTANT

Allow additional grout for bore hole irregularities, tremie tube retention and mixing/pumping equipment losses.

Anode Installation (Cathodic Protection)

Determining the number of Anodes: Total Green Mfg. uses a cathodic protection system (CPS) using one (CP1) or two (CP2) anodes and rectifier circuits depending on ground type composition. Use Chart 1 for selecting the appropriate cathodic protection system for your loop field installation.

Determining Number of Anodes	
Ground Make-Up	Number of Anodes
A 1 Soil Type & Solid Rock begins less than 5ft below grade	1 Sacrificial Bag Anode (allowed)
B 1 Soil Type & Solid Rock begins greater than 5ft below grade	1 Impressed Current Anode
C 1 Soil Type entire depth of borehole (0 Transitions - ex. 100% Clay)	1 Impressed Current Anode
D More than 1 Soil Type (1 Transition - ex. Clay to Sand)	1 Impressed Current Anode
E More than 2 types of Soil (Multiple Transitions - ex. Clay to Sand to Shale)	2 Impressed Current Anode
F Aggressive Soil(s) (Must Encased Loops in Sch. 21 PVC)	1 Impressed Current Anode

* If 2 anodes are needed, each anode requires a separate Rectifier & Power Supply

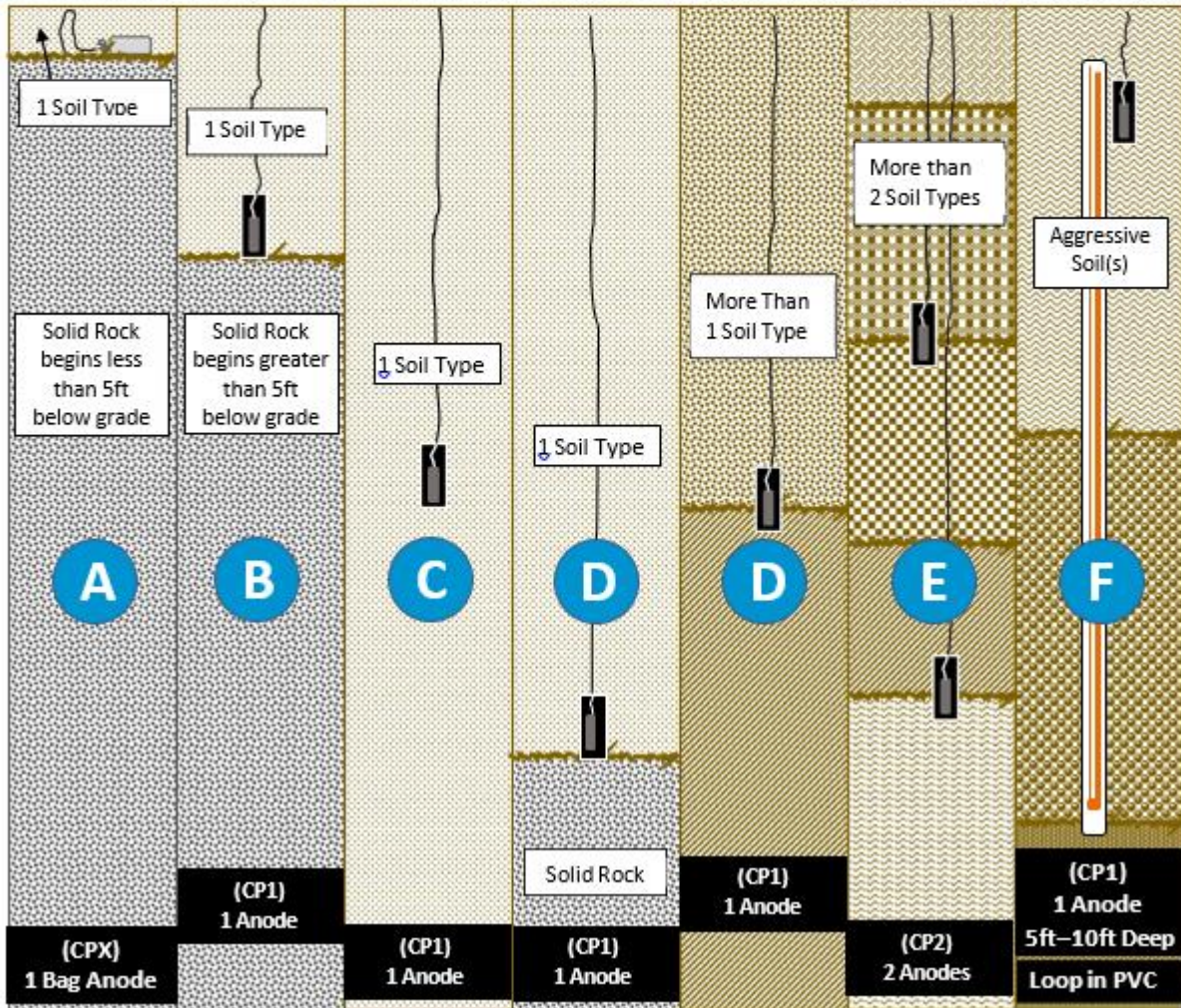

Chart 1

Anode Installation (Cathodic Protection)

Anodes will be placed at the bottom of the 3 to 4 inch bore holes drilled to the depth listed in [Chart 1](#). The anode boreholes will be located inside the manifold pit with in the radius of the loops. Please refer to [Figure 1](#).

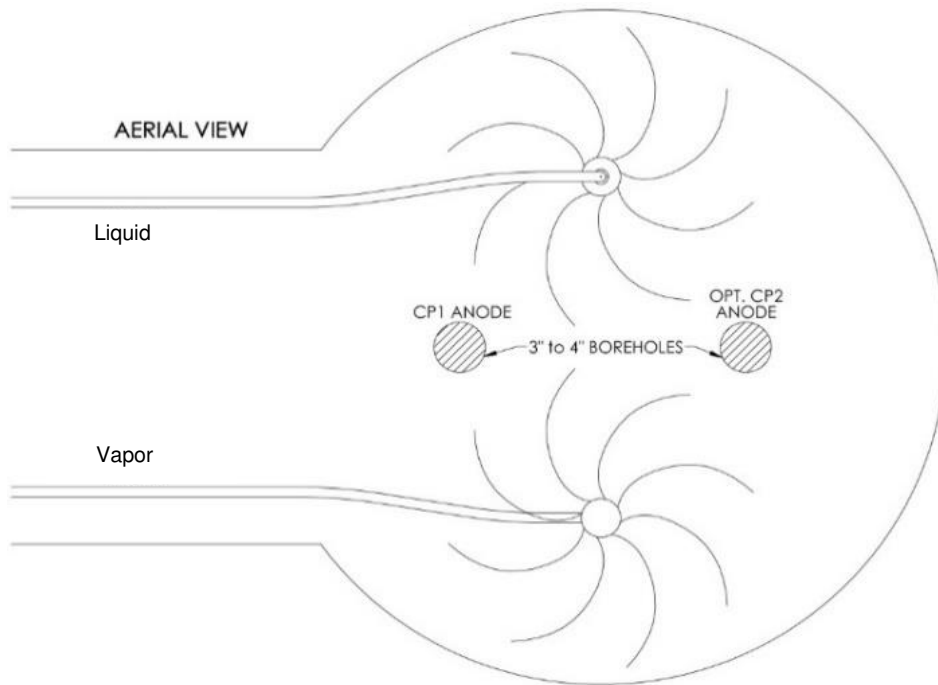

Figure 1

Once the anodes are in place, you must pack the anodes in Coke Breeze and back fill as per the following steps:

1. Mix water & coke using a paddle mixer.
2. Pour coke slurry down the hole – enough to surround the anode.
3. Fill with enough coke breeze to create a coke column that covers the entire anode from end to end. Typically a full bag.
4. Let all of the water absorb into the ground, allowing the granules to settle around the anode at the bottom of the hole.
5. Fill the hole with sand above the coke breeze to an approximate depth of 2 to 3 ft.
6. Fill the remaining borehole with grout.

Anode Installation (Cathodic Protection)

The anode wires will follow the line set back to the compressor unit location. Do not pull the anode wire taunt out of the borehole. Leave some slack to allow for expansion and contraction of the earth without stretching and possibly pulling the anode wire out of its casing. Follow the liquid line of the line set as the liquid line doesn't run as warm as the vapor line can. Building entry should be shared with the liquid line of the line set as well. Please refer to Figure 2.

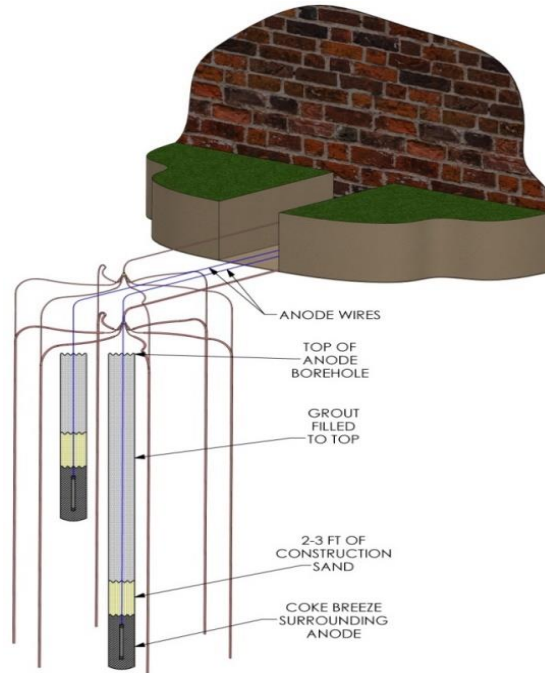

Figure 2

Manifold Installation

Manifold pit should be 4ft. deep or 18" below the frost line, which ever is greater.



WARNING

DO NOT CUT Earth Loop tubing unless it is first depressurized through the service valve.

Cutting pressurized tubing can cause bodily injury.

First, the liquid (smaller) earth loop tubing is cut, de-burred, cleaned and fit to the liquid manifold connections. 1/4 inch copper couplings may be needed and are field supplied. The liquid line of the field supplied manifold line set is de-burred, cleaned and connected to the main port on the liquid manifold, also cleaned. Be sure a sweeping pinwheel type arch is made to allow for expansion and contraction of the copper tubing. Failure to do so will result in leaks. Please refer to Figure 3 on page 26.



IMPORTANT

All refrigeration piping is to be brazed with 15% silver content brazing alloy utilizing the NITROGEN BRAZING PROCESS.



CAUTION

PURPOSE:

Utilize the **NITROGEN BRAZING PROCESS** on all brazed refrigerant piping connections. This process eliminates oxidation products from inside joint surfaces.

TECHNIQUE:

"Trickle" nitrogen gas at 1-2 psi pressure through the joint area being brazed, to displace the oxygen. When oxygen has been displaced, turn off the nitrogen, and relieve pressure at the joint to atmospheric prior to brazing.

CONSEQUENCES:

Failure to displace oxygen with nitrogen at the brazed joint will result in particulate matter being released into the system. The result is discoloration of refrigerant oil, contamination of the system and possible system failure.

The vapor (larger) manifold earth loop terminations and manifold line set connections are done after the liquid connections are brazed. Following the same de-burring and cleaning measures. 1/2" copper couplings may be needed and are field supplied. Be sure a sweeping pinwheel type arch is made to allow for expansion and contraction of the copper tubing. Failure to do so will result in leaks. Please refer to Figures 3A, 3B, 3C and 3D on page 25.

Please note: Any coupling, bushing or reducer to make earth loop to manifolds and line set to manifold connections may need to be field supplied.

Manifold Installation

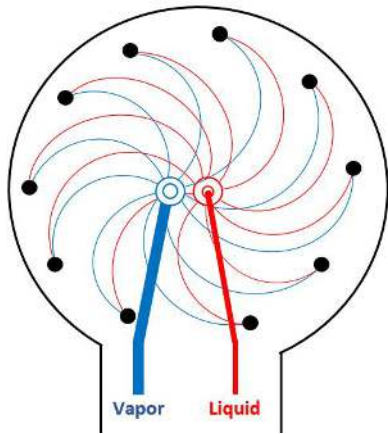

Figure 3A

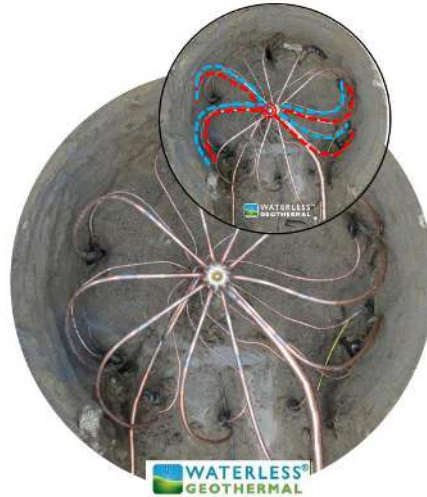

Figure 3B

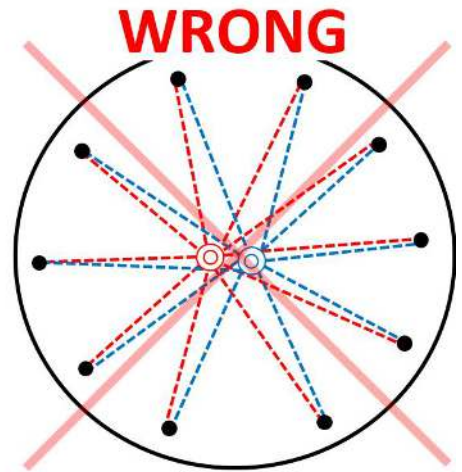

Figure 3C

Correct Field Installation:
Copper loops run to borehole with large radius bend.

Correct Field Installation:
Copper loops run to borehole with large radius bend.

WRONG Installation:
Copper loops run **straight** to borehole without large radius bend.

As seen in both the left and center picture above; a large radius bend in the copper ground loops leaves room for movement of the copper to take place and prevents the copper loops from kinking when the backfilled dirt settles. These large radius bends also allow for expansion and contraction of the copper as its temperature changes while the system is operating and, allows for movement of the soil as it freezes and thaws seasonally.

SIDE VIEW AS SEEN FROM TRENCH ENTRANCE

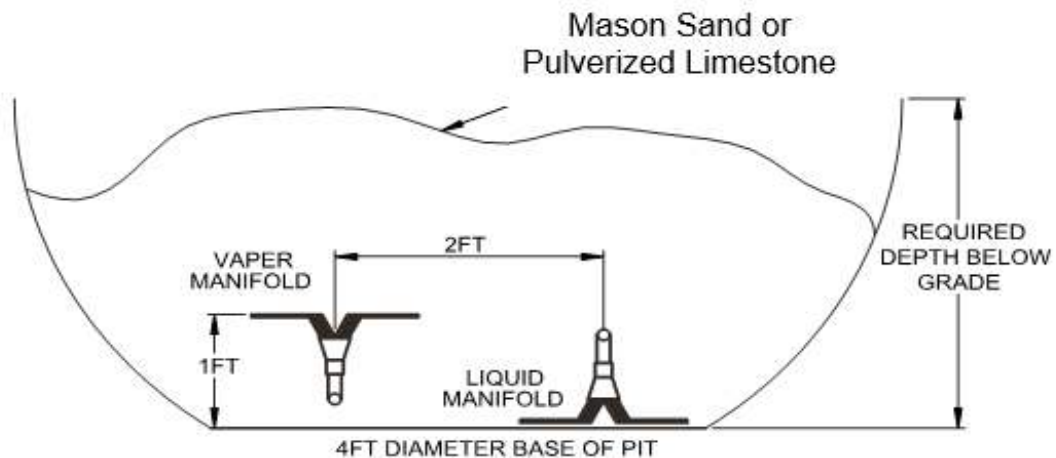

Figure 3D

Note: Manifolds may also be stacked as long as 2 ft. of separation between the two manifolds can be maintained.

Using a **permanent structure** as the basis for measurement, determine and record the distances A and B shown in Figure 4. After locating the manifolds per distances A and B, record this information for your record and provide a copy to your customer.

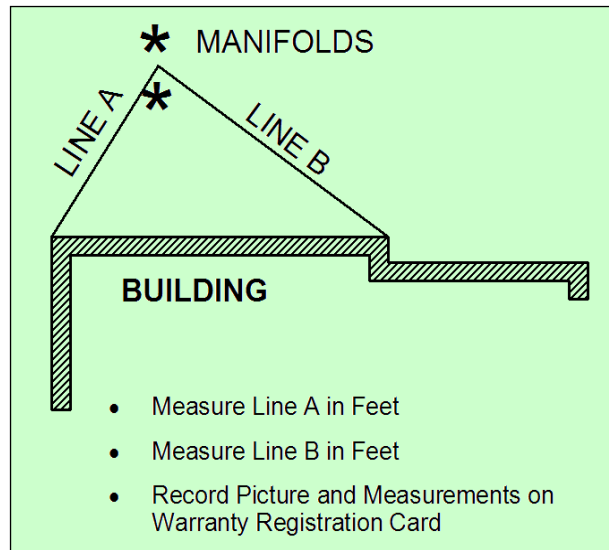

Figure 4

Soaker Line

Using field supplied 1/2" pex tubing; a soaker line should be created and installed as shown below. Plug off the end of the pex tubing laid out in the manifold pit. Roll out the remaining tubing into the line set trench exiting the ground just at the building entry or to the compressor unit location. Install a hose fitting on the end exiting the ground. Starting below ground in the trench nearest the building entry, drill an 1/8" hole all the way through the pex tubing every 24" all the way to the end of the tubing in the manifold pit.



Once backing filling is complete, attach a garden hose to the hose connection and run water to the soaker line overnight. Once the water is shut off, the water will perk away assisting in the compaction of the soil around the line set and manifolds. Having this soaker line gives the advantage of adding water to the ground to assist with cooling should long periods of excessively high outdoor temperatures occur or, as a service tool if needed.

Line Set



IMPORTANT!

WHEN A LINE SET IS RUN ALONG (PARALLEL TO, NOT THROUGH) A FOUNDATION, THE MINIMUM DISTANCE BETWEEN THE LINE SET AND THE FOUNDATION IS 12 FEET.

All Manifold/Earth Loop line sets are **field supplied** and should be selected in accordance to Chart 2 below.

R410A EARTHLOOP, AIR HANDLER, CASED COIL LINE SETS		
COMPRESSOR UNIT SIZE	R410A LINE SET O.D., INCHES	
	LIQUID	VAPOR
2.0 Tons (-024)	3/8	3/4
2.5 Tons (-030)	3/8	3/4
3.0 Tons (-036)	3/8	3/4
3.5 Tons (-042)	1/2	7/8
4.0 Tons (-048)	1/2	7/8
4.5 Tons (-054)	1/2	7/8
5.0 Tons (-060)	1/2	7/8
5.5 Tons (-066)	1/2	1-1/8
6.0 Tons (-072)	1/2	1-1/8

Chart 2

Prior to or after brazing the earth loop and line set to the manifolds, the line set should be installed and run to the location of the compressor unit. The methods are shown in Figure 5.

- Line set trench should be free of rocks, sharp objects and other foreign debris.
- Tubing bends should have a long radius of at least 12”.
- Minimum line set separation is 12”.
(We recommend 24”)
- Line set must be insulated when within 12’ of the house.
- Insulated the vertical rise.
- The line set, both liquid and vapor, must be insulated with at least 1/2” wall thickness Armaflex, Insul-Tube or equivalent insulation when within 12 feet of the building entry. The remaining line set to the manifolds will **NOT** be insulated.

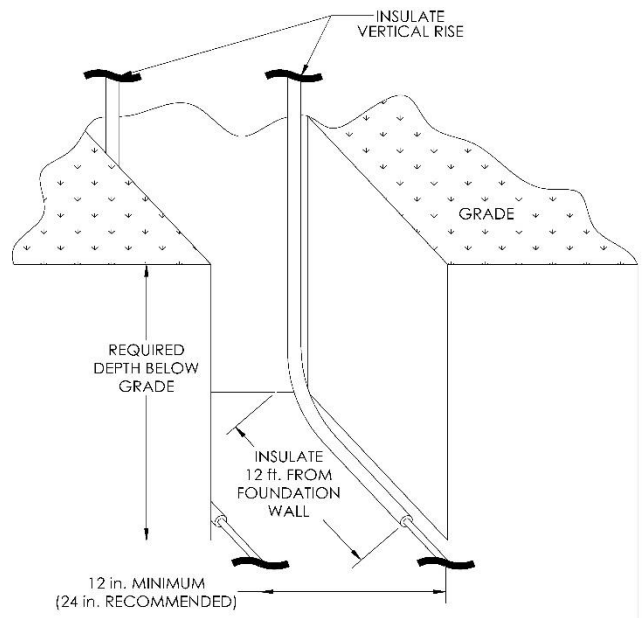

Figure 5

Line Set



IMPORTANT!

FOR ALL EARTH LOOP SYSTEMS, THE LINE SET AND MANIFOLDS SHALL BE AT LEAST 4-5 FEET BELOW GRADE OR 1-1/2 FEET BELOW THE LOCAL FROST LINE, WHICHEVER IS DEEPER.

If the compressor unit is to be placed outdoors, the line set is brought up through the ground adjacent to the compressor unit backside (nearest the wall), **maintaining separation of the insulated refrigerant lines.**

If the compressor unit is to be placed indoors, the line set must be run through or under an outer wall to the compressor unit location. The following guidelines are to be used in conjunction with Figure 6 on page 29.

1. Enter the building above grade, if possible.
2. Below grade entry is a source for basement wall leakage. Seal with flexible sealant that maintains a tight seal for temperatures from -20°F to +200°F and adheres to all materials involved.

To seal around the outside of the PVC pipe at the building entry shown in Figure 9 on page 21, any one of the following sealants is recommended:

- Loctite POLYSEAMSEAL Caulk and All Purpose Adhesive Caulk
- DAP DYNAFLEX 230 Premium Interior/Exterior Latex Sealant
- 3M Polyurethane Mason Sealant 525

To foam the insulated line set tubes inside the PVC sleeve shown in Figure 6A/B, 7 and 8 on pages 30, 31 and 32.

The following airtight and waterproof sealant is recommended to fill the inside of the sleeve:

- Dow Insulating Foam Sealant (“Great Stuff”, #7498500154)



IMPORTANT!

It is noted that after the insulated vapor and liquid lines enter the building they must continue to be separated by an air space from the point of building entry to the compressor unit.

Braze a service valve into the vapor line termination and a cap onto the liquid line termination as shown in Figure 9 on page 31.

Line Set

Penetration above Ground

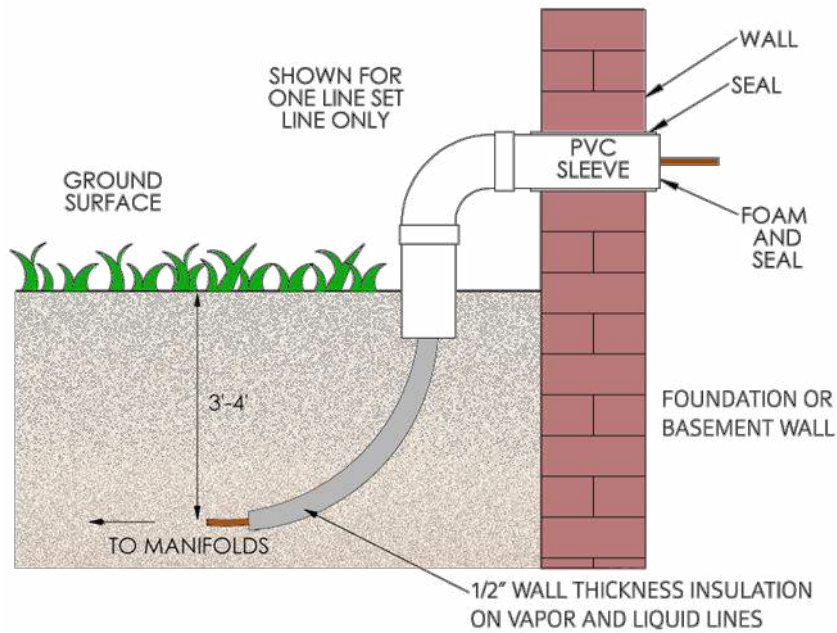

Figure 6A

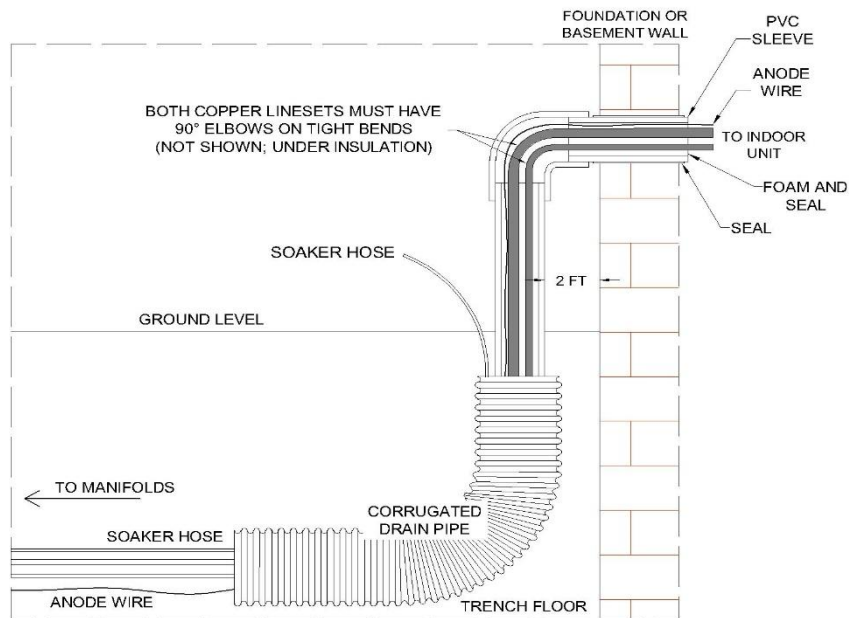

Figure 6B

Note: Corrugated drain pipe can be used as an option for extra protection of the line set if needed for protection against rocks or rocky soil. It should also be used under driveways or slabs to ease removal and/or replacement of line sets if needed without cutting or busting up concrete. Figure 6B on this page and figures 7 and 8 on pages ahead show the optional corrugated drain pipe.

Line Set

Penetration From Below Ground through Floor Joist

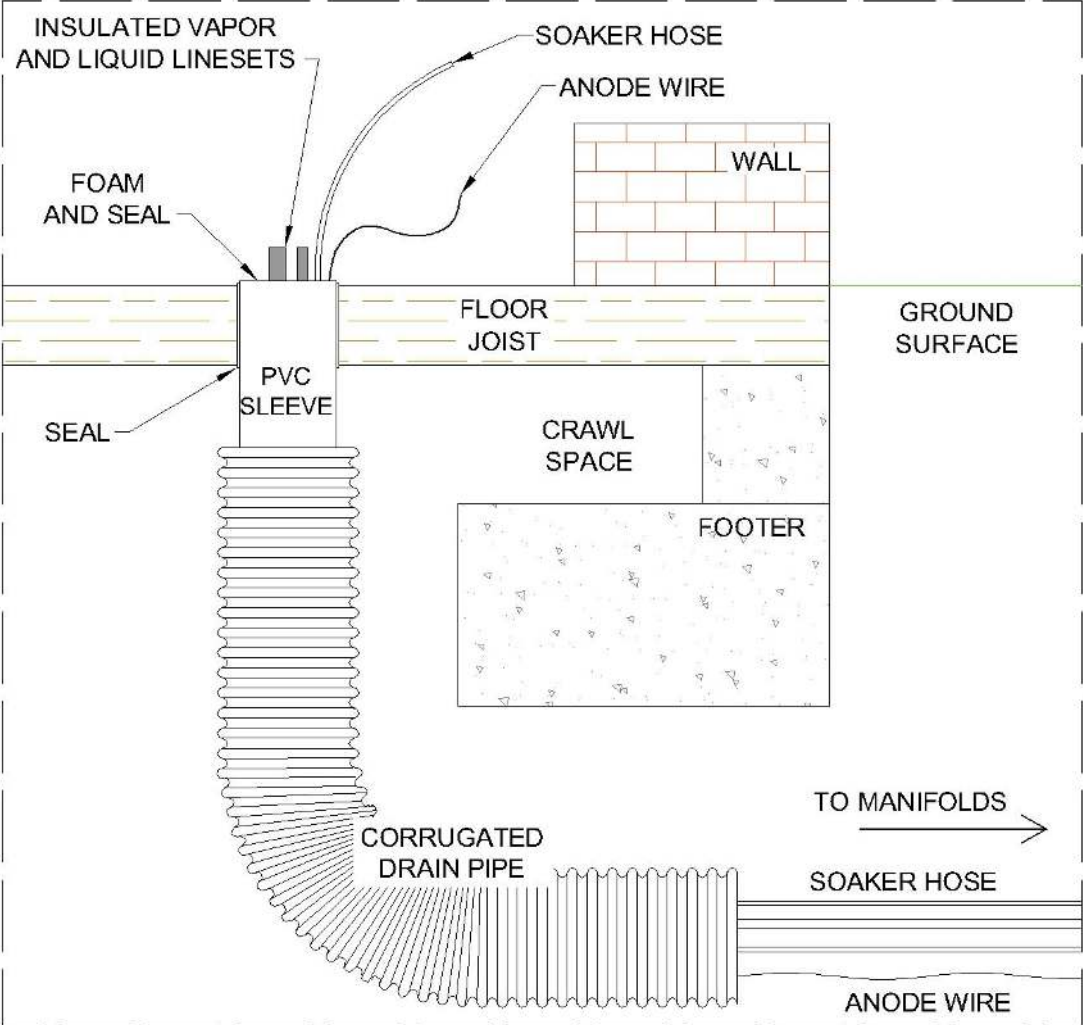

Figure 7

Line Set

Penetration From Below Ground through Slab

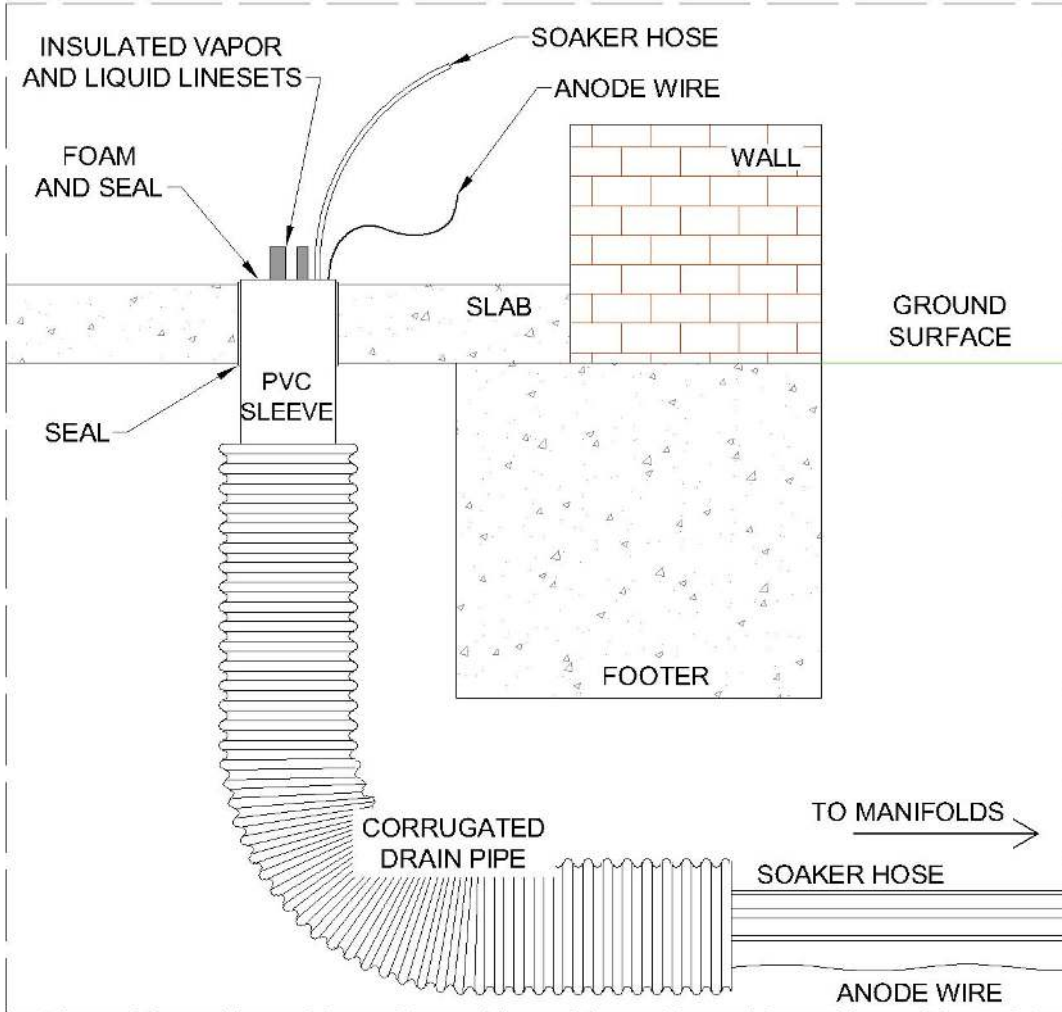

Figure 8

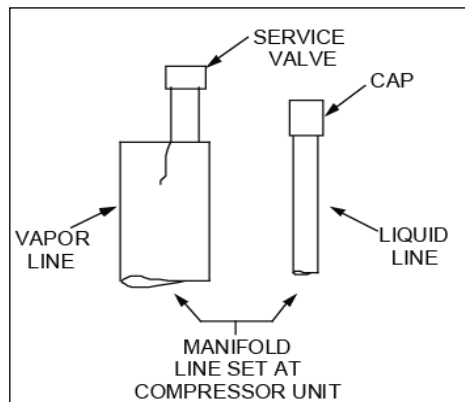

Figure 9

Seal Test



WARNING!

To avoid personal injury and equipment damage, follow all safety procedures set forth by OSHA, in the handling of high pressure gases. Always use a pressure regulator and hoses that are capable of withstanding the pressures prescribed herein. Do not subject system components OTHER than the earth loop/manifold/line set configuration to 400 PSIG nitrogen.

After brazing the earth loop system joints as noted above (includes manifolds, earth loops and earth loop line set, but NOT the compressor unit or any other HVAC refrigeration system component), the complete underground system is to be seal tested with 400 PSIG nitrogen. After connecting a high pressure hose from the regulator on the nitrogen tank to the service valve on the vapor line of the line set, slowly increase the nitrogen pressure to 400 PSIG, checking for any obvious leaks audibly.

If no audible leaks are detected, check all joints to ensure they are sealed, by one of the following methods:

1. Ultrasonic Leak Detector or Bubble Solution Leak Detector
2. Electronic Leak Detector (requires a trace amount of refrigerant in the system)



IMPORTANT – LOOP READINESS

Check for leaks by either of these methods or any other reliable method to ensure that there are no leaks and the earth loop system is sealed! It is absolutely necessary that the earth loop/manifold/line set assembly be completely sealed at 400 psig nitrogen. Recheck all leak detector readings.

When the Earth Loop System (earth loops, manifolds and line set assembly) has been successfully seal tested, **leave 400 psig nitrogen with pressure gauge on the service valve in Figure 7 on page 29.** This indicates the Earth Loop System has been installed; seal checked and is ready for the compressor unit connection.

When the line set/manifolds/earth loops are deemed leak free and sealed, **valve off the nitrogen source and monitor the pressure on the underground system to ensure that 400psig has been maintained for minimum of 8 hours.**

Monitor the pressure reading during the backfilling operation to ensure that the earth loop system remains sealed.

Important: Final Whole System Seal Test.

After having tested the field at 400 P.S.I. as stated above, once the remaining equipment such as the compressor unit, air handler or cased coil, ETC, the entire system should be pressurize to 150 P.S.I. and left to stand for a min. of 8 hours for a total system seal test.

Backfilling

Prior to backfilling the manifold pit for vertical or diagonal systems, shown in Figure 3 on page 14, add water to the pit, covering the manifolds. The water in the pit will ensure firm compaction of the sand or Pulverized limestone that is to be packed around the manifolds and earth loop connections. Carefully pack mason sand or Pulverized limestone around the manifolds to ensure that the manifolds are firmly oriented as shown in Figure 3D on page 25 (manifolds are shown with proper spacing and orientation, and manifold bodies are VERTICAL as shown).

Ensure that enough sand or Pulverized limestone is packed around the manifolds/earth loops/line sets that backfilling will not move them from the indicated positions of Figure 3D on page 25.



CAUTION

Failure to surround and pack the manifold pit assembly with sand as shown in Figure 3 will negatively impact system performance and may cause a leak in the earth loop. It will void the Earth Loop warranty.

Backfill the line set trench with excavated fill if there are no rocks or sharp objects. If the backfill has rocks and/or sharp objects, fill the line set trench with 2" of mason sand or Pulverized limestone under and over the line set and then carefully backfill the excavated trench.

Please Note: The line set needs to be as straight as possible. Dips in the line set could create an unwanted oil trap starving the compressor for oil.

Please call Total Green Mfg. at 419-678-2032 with any questions regarding these procedures.



IMPORTANT!

If any specifications in this manual cannot be met, contact Total Green Mfg. for a possible solution and approval. Any approved solutions that differ from the specifications in this manual must be approved with a written variance from Total Green Mfg.

R-410A QUICK REFERENCE GUIDE

- R-410A refrigerant operates at 50% – 70% higher pressures than R-22. Be sure that servicing equipment and replacement components are designed to operate with R-410A.
- R-410A systems should be charged with liquid refrigerant only.
- R-410A is only compatible with POE oil. The oil used in a Waterless® Geothermal system is **Copeland Ultra 32-3 MAF**. Using any other brand or type will void the manufacturer's equipment warranty.
- POE oils absorb moisture rapidly. Do not expose oil to atmosphere. Always flow nitrogen anytime a system is open to prevent atmosphere from entering any part of the system.
- Vacuum pumps will not remove moisture from oil.
- Never open system to atmosphere while it is under a vacuum.
- A liquid line filter drier is required on every unit.
- Wrap all filter driers and service valves with wet cloth when brazing.
- When system must be opened for service, break vacuum with dry nitrogen and replace all filter driers.
- Wrap all filter driers and service valves with wet cloth when brazing.
- Do not vent R-410A into the atmosphere.